

COMMERCIAL PERFORMANCE NOW AVAILABLE FOR YOUR HOME



1020

AFNE9B

689

TESTED TO OUTLAST

We still make them like we used to. Built to last up to 25 years in the home - 10,400 cycles.

Components include heavy-duty door hinge, heavy-duty variable induction drive system, metal trunnion, bearing and driveshaft, with heavy-duty seal and bearing assembly and aluminium pulley.

DURABLE

Three-coat, commercial-grade steel cabinet will look good for years to come, whilst full metal base provides stability and noise suppression.

EXTRA CAPACITY

Large 96.8 litre stainless steel tub, constructed for increased washing performance and water extraction, with 180° swing door.

ENERGY EFFICIENT

Dynamic balancing, Incredible 440 G-force and 1,200rpm spin speed for optimum water extraction, and a spray rinse for outstanding results and water saving.

COMMERCIAL GRADE

Commercial heavy-duty motor with out-of-balance logic and heavy-duty commercial shock absorbers for strength and durability.

DYNAMIC WASH CYCLES

Cycles to suit your lifestyle, Quick Wash, Light, just 24min.

TOUCH FRONT LOAD WASHER

MODEL NUMBER	AFNE9BSP305AW01	ADDITIONAL OPTIONS	Soak, Pre-Wash, Second Rinse, Third Rinse, Delay Start, Signal finish
CAPACITY KG	10 kg	WATER PRESSURE KPA(Psi)	138-830 (20-120)
DRUM CAPACITY LITRES	96.8 L	CYCLE INDICATOR LIGHTS	Yes
DIMENSIONS (H X W X D)	1027 x 683 x 704 mm	WASH TUB	Stainless
SPIN SPEED G-FORCE (RPM)	440 (1200)	OUTER WASH TUB	Stainless
MOTOR SIZE KW (WATTS)	750 W (Variable Speed)	ELECTRICAL REQUIREMENTS (VOLTAGE/HZ/PH)	240 V / 50 Hz AC / 1 Ph
WATER CONSUMPTION PER CYCLE LT	126 L	SHIPPING DIMENSIONS (H X W X D)	1156 x 732 x 832 mm
WATER TEMPERATURE SELECTION	4	SHIPPING WEIGHT	122 kg
AVAILABLE CYCLES	Heavy Duty, Normal Eco, Perm Press, Delicate, Rinse & Spin, Spin Only, Whites, Bulky, Quick & Favourite cycle		

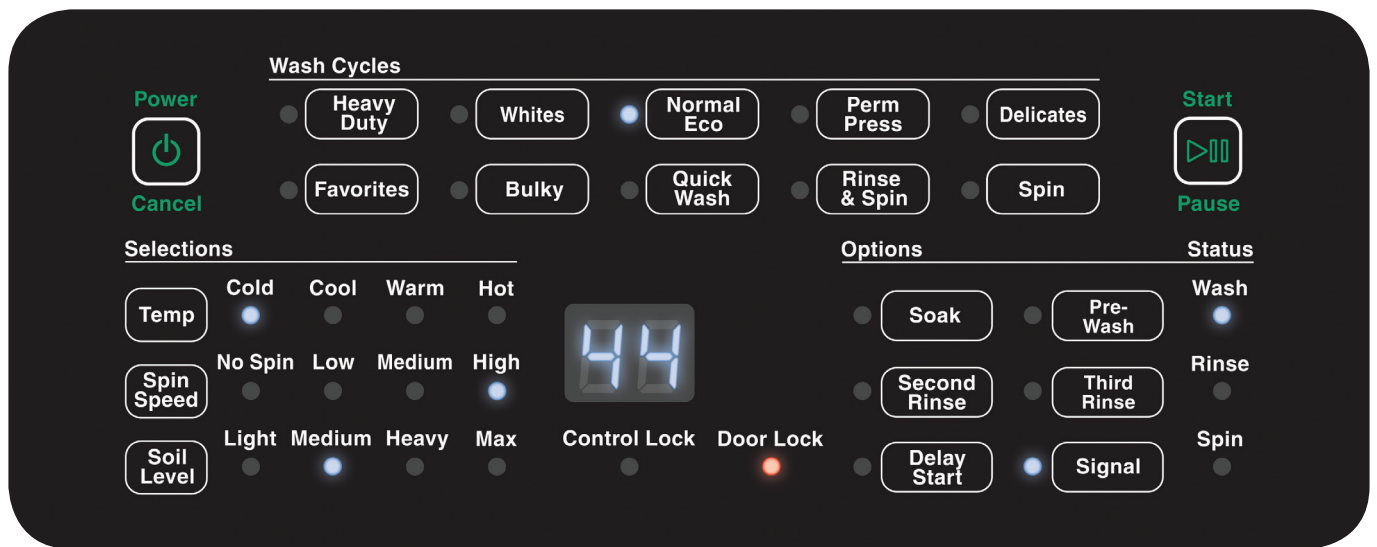

Image, price and information are subject to change without notice.

SPEED QUEEN FRONT LOAD EFFICIENCY

SCHEMATICS

TOUCH WASHER

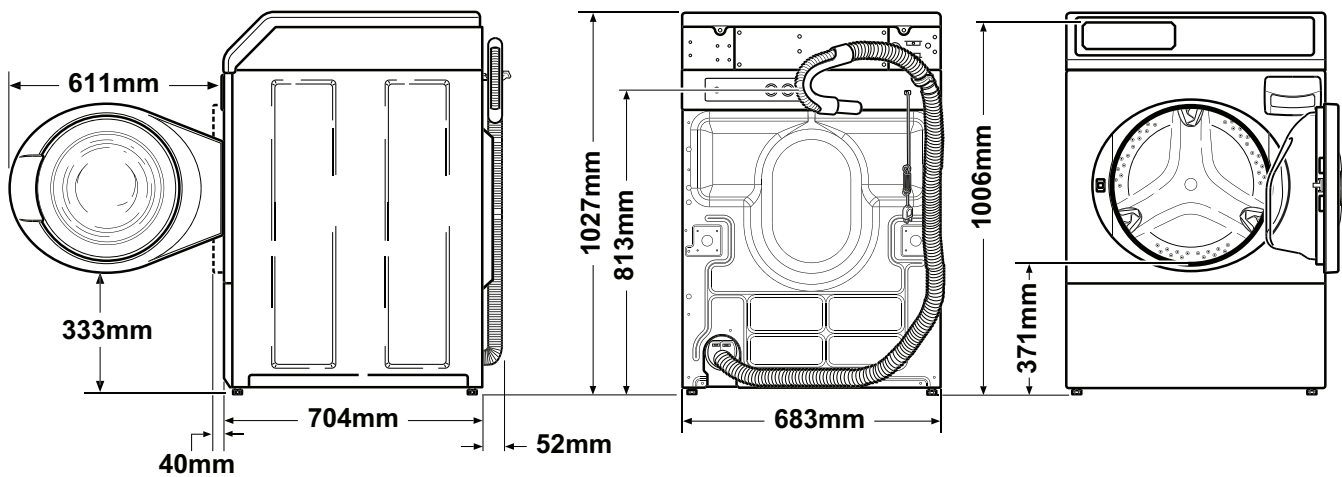

To learn more about Speed Queen's century of uncompromising performance and reliability, visit speedqueen.com.au or call 1300 WASHER (1300 927 437) today.

Five year warranty on all parts and labour.

For the most accurate information, the installation guide should be used for all design and construction purposes. Due to continuous product improvements, design and specifications are subject to change without notice, the quality management system of Alliance Laundry Systems' Ripon facility has been registered to ISO 9001-2000.





Tested to Outlast

We still make them like we used to. Tested for 10,400 cycles which could be up to 25 years in the home. Our touch pads are tested for 1 million impressions.

Durable

Triple Coated, commercial-grade steel cabinet will look good and last for years to come.

Extra Capacity

Large 198 litre capacity cylinder with the largest door opening means it can handle the biggest loads, so you spend less time in the laundry.

Fabric Care

Whisper quiet, superior airflow of 85 litres per second results in faster drying with less wear, and less wrinkling of clothes.

Energy Efficient

Three temperature setting options and auto dry feature ensure the dryer does not over dry items wasting valuable time, energy and money.

Convenient Cycle Times

From 35min for full 9 kg load.

ADEE8B ELEC & ADGE8B GAS BLACK

SPEEDQUEEN.COM.AU

ADEE8B ELEC & ADGE8B GAS BLACK

Model Numbers	ADEE8B Black (Electric) ADGE8B Black (Gas)
Capacity	9 kg
Quiet, Efficient Blower	Yes
Dimensions (H X W X D)	1027 x 683 x 711 mm
Dryer Drum Capacity (Litres)	198 L
Dryer Door Width	525 mm
Dryer Door Hinge	Reversible
Dryer Motor Horsepower	1/3 hp
Available Heat Sources	Electric or Gas (NG or LP)
Electrical Requirements (Voltage/Hz/Ph)	240V / 50 Hz AC / 1 Ph
Dryer Breaker Size	20 (Electric) 10 (Gas) Amps
Gas Consumption Mj	21.1 MJ (Gas)
Temperature Settings	3
Available Cycle	Regular, Perm Press, Delicate, Time Dry, Quick Dry & Fluff up cycles

Moisture Sensor	Yes
Shoe Dryer Rack	Optional (part number 512082)
Cabinet	Triple Coated Galvanised Steel
Drum	Galvanised Steel
Cycle Indicator Light	Yes
End-Of-Cycle Buzzer	Yes
Automatic Dry Cycles	Yes
Time Drying	Yes
Gas Inlet Connection	3/8 NPT
Heating Element	4000 W (Electric)
Multiple Vent Options	Yes
Exhaust Vent Size	102 mm
Australian Gas Approval	Yes
Lp Conversion Kit	Optional
Shipping Dimensions (H X W X D)	1156 x 760 x 860 mm
Shipping Weight	Electric - 70 kg Gas - 73 kg

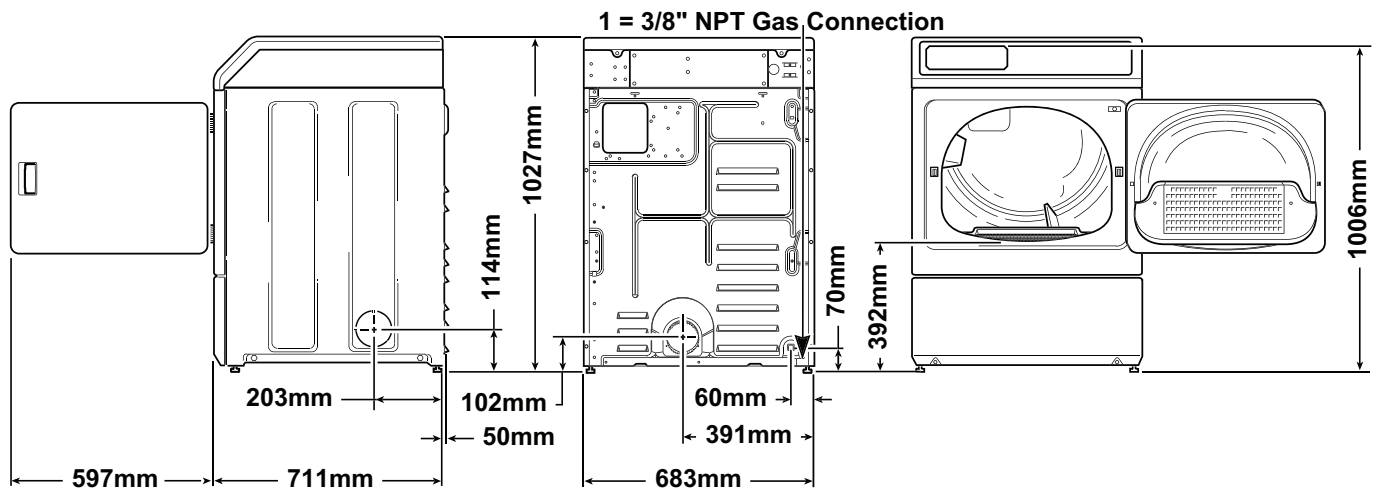
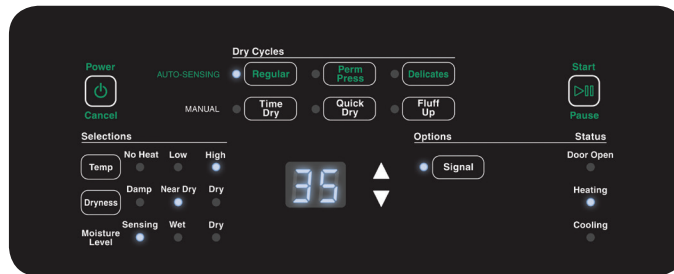

FRONT CONTROL DRYER