

AWNA62 BLACK

Tested to Outlast

We still make them like we used to. Tested for 10,400 cycles which could be up to 25 years in the home.

Extra Capacity

Large 92 litre stainless steel tub won't corrode, chip, pit or crack. It's not only gentler on clothes, but both the inner and outer tub come with a lifetime warranty.

Wash Quality

Traditional full-sized flex vane agitator with extra-large 210° agitation arc, with 68 agitations per minute, provides superior wash performance.

Durable

Triple coated, commercial-grade steel cabinet will look good for years to come, whilst full metal base provides stability and noise suppression.

Commercial Grade

Heavy duty, all metal transmission and industrial strength motor as used in laundrettes world wide.

Fast Cycle Times

Regular cycle, normal wash - 37 minutes.

SPEEDQUEEN.COM.AU

Model Numbers	AWNA62 Black
Capacity	8.5 kg
Drum Capacity Litres	92.3 L
Dimensions (H X W X D)	1092 x 651 x 711 mm
Spin Speed (Rpm)	710 / 473 RPM
Agitation Rate	68/44 per minute
Motor Size Kw (Hp)	0.37 (1/2)
Motor Speeds	2
Water Consumption High Efficiency Cycle (Avg)	117 L
Variable Water Level Selection	Yes
Available Cycles	Normal, Perm Press, Delicate, Rinse, Rinse & Spin, Spin only
Wash Options	Regular or High Efficiency

Water Temperature Selection	3
Water Pressure Kpi (Psi)	140-830 (20-120)
Bleach Dispenser	Yes
Fabric Softener Dispenser	Yes
Wash Tub	Stainless Steel
Outer Wash Tub	Porcelain Steel
Cabinet	Triple Coated Galvanised Steel
Electrical Requirements (Voltage/Hz/Ph)	240 V / 50 Hz AC / 1 Ph
Fill Hoses Included	Yes, 1.2 Mtrs
Automatic Balancing System	Yes
Rear Self-Levelling Legs	Yes
Shipping Dimensions (H X W X D)	1156 x 700 x 780 mm
Shipping Weight	89 kg

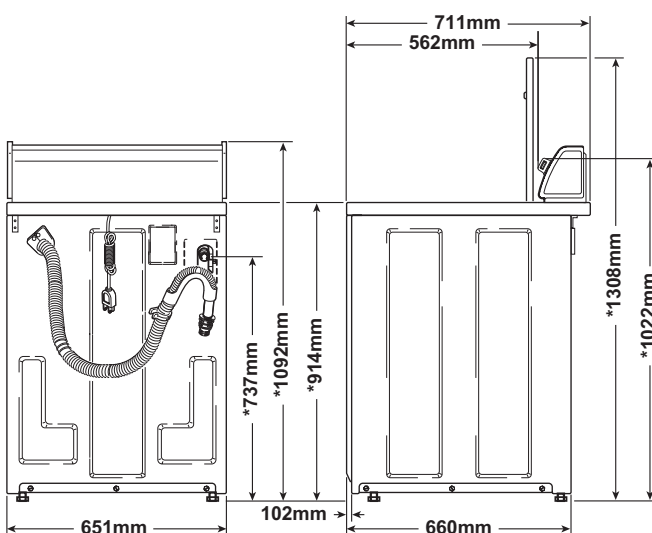

TOP LOAD

COMMERCIAL QUALITY FOR MORE THAN A CENTURY

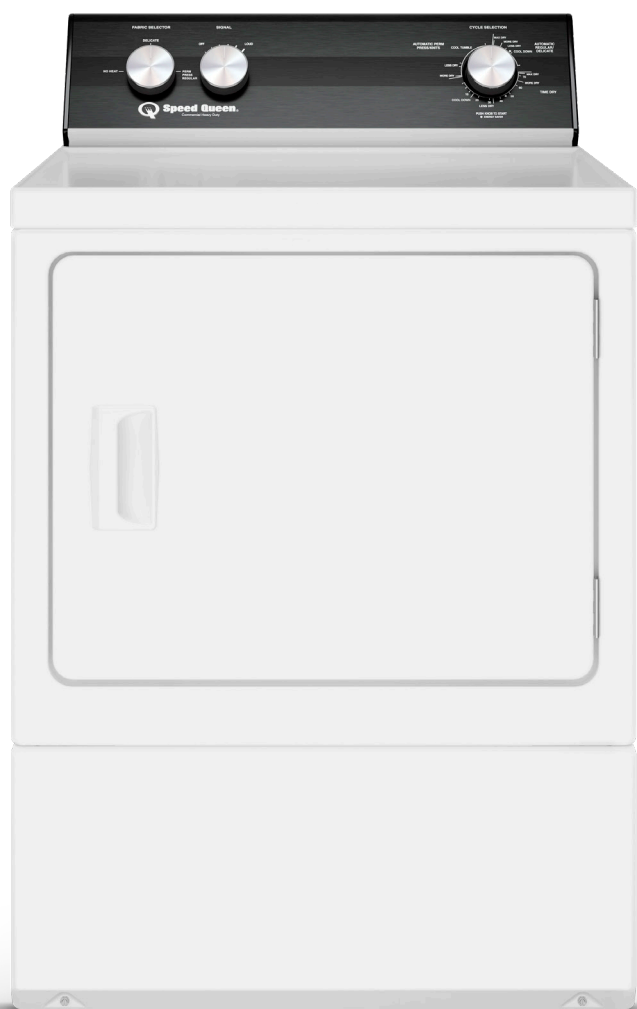

Tested to Outlast

We still make them like we used to. Tested for 10,400 cycles which could be up to 25 years in the home.

Durable

Triple coated, commercial-grade steel cabinet will look good and last for years to come.

Extra Capacity

Large 198 litre capacity cylinder, rated to 9kg with the largest door opening means it can handle the biggest loads, so you spend less time in the laundry.

Fabric Care

Whisper quiet, superior airflow of 85 litres per second results in faster drying with less wear, and less wrinkling of clothes.

Energy Efficient

Three temperature setting options and auto dry feature ensure the dryer does not over dry items wasting valuable time, energy and money.

Fast Cycle Times

From 35min for full 9 kg load.

ADE3TR ELEC & ADG3TR GAS BLACK

SPEEDQUEEN.COM.AU

ADE3TR ELECTRIC & ADG3TR GAS BLACK

Model Numbers	ADE3TR Black (Electric) ADG3TR Black (Gas)
Capacity	9 kg
Quiet, Efficient Blower	Yes
Dimensions (H X W X D)	1,092 x 683 x 711 mm
Dryer Drum Capacity (Litres)	198 L
Dryer Door Width	525 mm
Dryer Door Hinge	Reversible
Dryer Motor Horsepower	1/3 hp
Available Heat Sources	Electric or Gas (NG / LP)
Electrical Requirements (Voltage/Hz/Ph)	240V / 50 Hz AC / 1 Ph
Dryer Breaker Size	20 (Electric) 10 (Gas) Amps
Gas Consumption Mj	21.1 MJ (Gas)
Temperature Settings	3
Available Cycles	Regular, Perm Press & Time Dry

Shoe Dryer Rack	Optional (part number 512082)
Cabinet	Triple Coated Galvanised Steel
Drum	Galvanised Steel
End-Of-Cycle Buzzer	Yes
Automatic Dry Cycles	Yes
Time Drying	Yes
Gas Inlet Connection	3/8 NPT
Heating Element	4000 W (Electric)
Multiple Vent Options	Yes
Exhaust Vent Size	102 mm
Australian Gas Approval	Yes
LP Conversion Kit	Optional
Shipping Dimensions (H X W X D)	1156 x 737 x 832 mm
Shipping Weight	65 kg

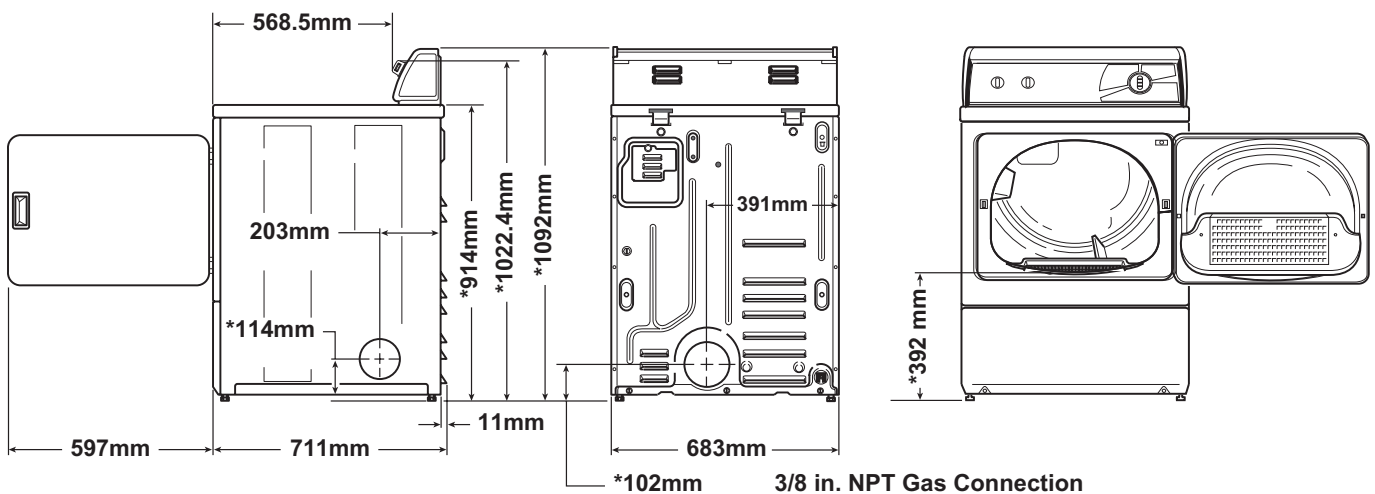

REAR CONTROL DRYER